

Part number:

**HYDROMA**

HYDRAULICKÉ SYSTÉMY

**HIDROMA  
SYSTEMS**

UKŁADY HYDRAULICZNE

**HYDROMA**

ГИДРАВЛИЧЕСКИЕ СИСТЕМЫ

## HYDRAULIC MOTORS MT



### APPLICATION

- » Conveyors
- » Metal working machines
- » Machines for agriculture
- » Road building machines
- » Mining machinery
- » Food industries
- » Special vehicles
- » Plastic and rubber machinery etc.

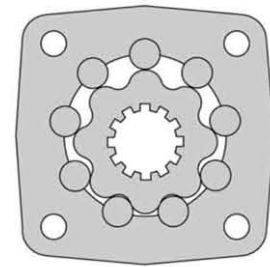

### CONTENTS

Specification data .....	30
Function diagrams .....	31 ÷ 33
Dimensions and mounting .....	34
Shaft extensions .....	35
Dimensions and mounting- MTS, V .....	36 ÷ 37
Internal Spline data .....	38
Permissible shaft loads .....	38
Tacho connection .....	39
Order code .....	39

### OPTIONS

- » Model- Disc valve, roll-gerotor
- » Flange with wheel mount
- » Short motor
- » Tacho connection
- » Speed sensing
- » Side and rear ports
- » Shafts- straight, splined and tapered
- » Metric and BSPP ports
- » Other special features

### GENERAL

Displacement, [cm <sup>3</sup> /rev.]	161,1 ÷ 523,6
Max. Speed, [RPM]	240 ÷ 625
Max. Torque, [daNm]	47 ÷ 122
Max. Output, [kW]	26,5 ÷ 33,5
Max. Pressure Drop, [bar]	160 ÷ 200
Max. Oil Flow, [l/min]	100 ÷ 125
Min. Speed, [RPM]	5 ÷ 10
Permissible Shaft Loads, [daN]	P <sub>0</sub> = 1000
Pressure fluid	Mineral based- HLP(DIN 51524) or HM(ISO 6743/4)
Temperature range, [°C]	-30 ÷ 90
Optimal Viscosity range, [mm <sup>2</sup> /s]	20 ÷ 75
Filtration	ISO code 20/16 (Min. recommended fluid filtration of 25 micron)

#### Oil flow in drain line

Pressure drop (bar)	Viscosity (mm <sup>2</sup> /s)	Oil flow in drain line (l/min)
140	20	2,5
	35	1,5
210	20	5
	35	3

#### Pressure Losses

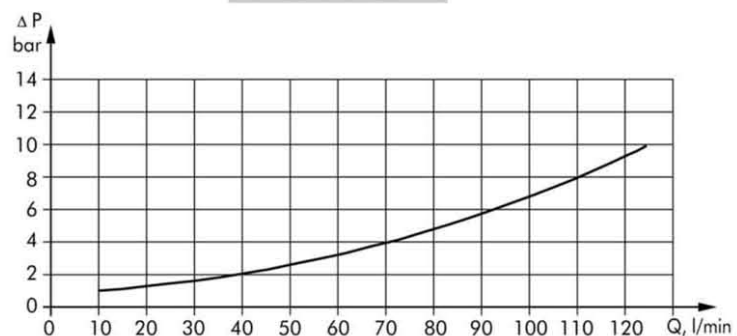

## SPECIFICATION DATA

Type		MT 160	MT 200	MT 250	MT 315	MT 400	MT 500
Displacement [cm <sup>3</sup> /rev.]		161,1	201,4	251,8	326,3	410,9	523,6
Max. Speed, [RPM]	cont.	625	625	500	380	305	240
	Int.*	780	750	600	460	365	285
Max. Torque [daNm]	cont.	47	59	73	95	108	122
	Int.*	56	71	88	114	126	137
	peak**	66	82	102	133	144	160
Max. Output [kW]	cont.	26,5	33,5	33,5	33,5	30	26,5
	int.*	32	40	40	40	35	30
Max. Pressure Drop [bar]	cont.	200	200	200	200	180	160
	Int.*	240	240	240	240	210	180
	peak**	280	280	280	280	240	210
Max. Oil Flow [l/min]	cont.	100	125	125	125	125	125
	Int.*	125	150	150	150	150	150
Max. Inlet Pressure [bar]	cont.	210	210	210	210	210	210
	Int.*	250	250	250	250	250	250
	peak**	300	300	300	300	300	300
Max. Return Pressure without Drain Line or Max. Pressure in Drain Line , [bar]	cont. 0-100 RPM	75	75	75	75	75	75
	cont. 100-300 RPM	40	40	40	40	40	40
	cont. >300 RPM	20	20	20	20	20	-
Max. Return Pressure with Drain Line [bar]	Int.* 0-max. RPM	75	75	75	75	75	75
	cont.	140	140	140	140	140	140
	Int.*	175	175	175	175	175	175
Max. Starting Pressure with Unloaded Shaft, [bar]		10	10	10	10	10	10
Min. Starting Torque [daNm]	at max. press. drop cont.	34	43	53	74	84	95
	at max. press. drop Int.*	41	52	63	89	97	106
Min. Speed***, [RPM]		10	9	8	7	6	5
Weight, [kg]	MT	20	20,5	21	22	23	24
	MTW	22	22,5	23	24	25	26
	MTS	15	15,5	16	17	18	19
	MTV	11	11,5	12	13	14	15

\* Intermittent operation: the permissible values may occur for max. 10% of every minute.

\*\* Peak load: the permissible values may occur for max. 1% of every minute.

\*\*\* For speeds of 5 RPM lower than given, consult factory or your regional manager.

- 1) Intermittent speed and intermittent pressure must not occur simultaneously.
- 2) Recommended filtration is per ISO cleanliness code 20/16. A nominal filtration of 25 micron or better.
- 3) Recommend using a premium quality, anti-wear type mineral based hydraulic oil, HLP(DIN51524) or HM(ISO6743/4).  
If using synthetic fluids consult the factory for alternative seal materials.
- 4) Recommended minimum oil viscosity 13 mm<sup>2</sup>/s at 50°C.
- 5) Recommended maximum system operating temperature is 82°C.
- 6) To assure optimum motor life fill with fluid prior to loading and run at moderate load and speed for 10-15 minutes.

## FUNCTION DIAGRAMS

### MT 160

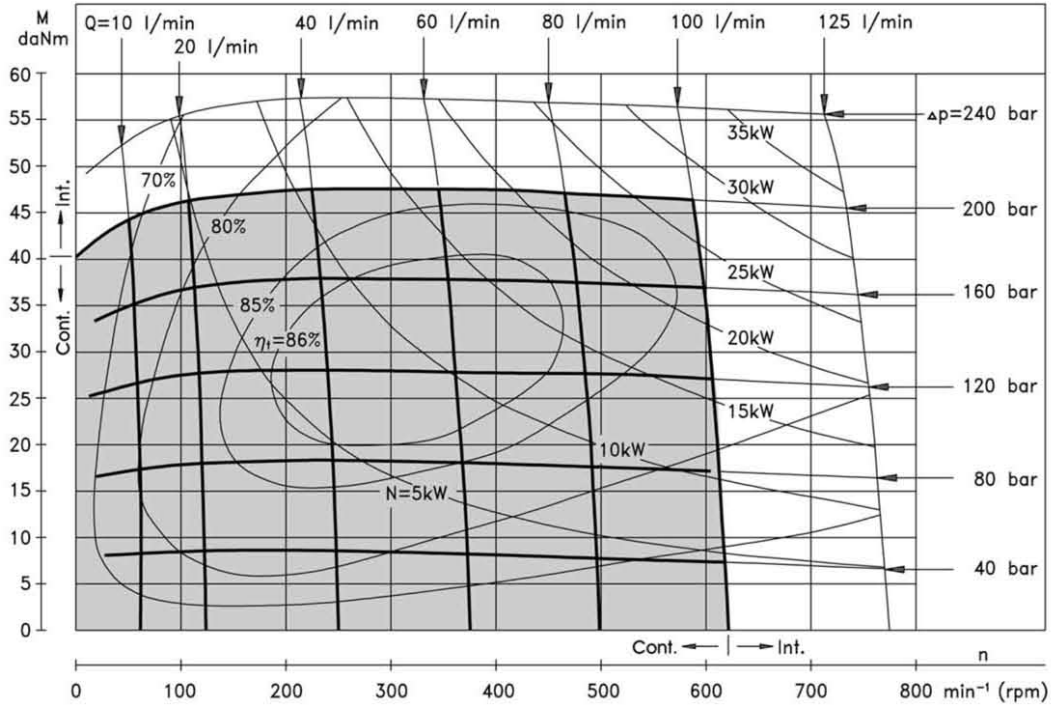

### MT 200

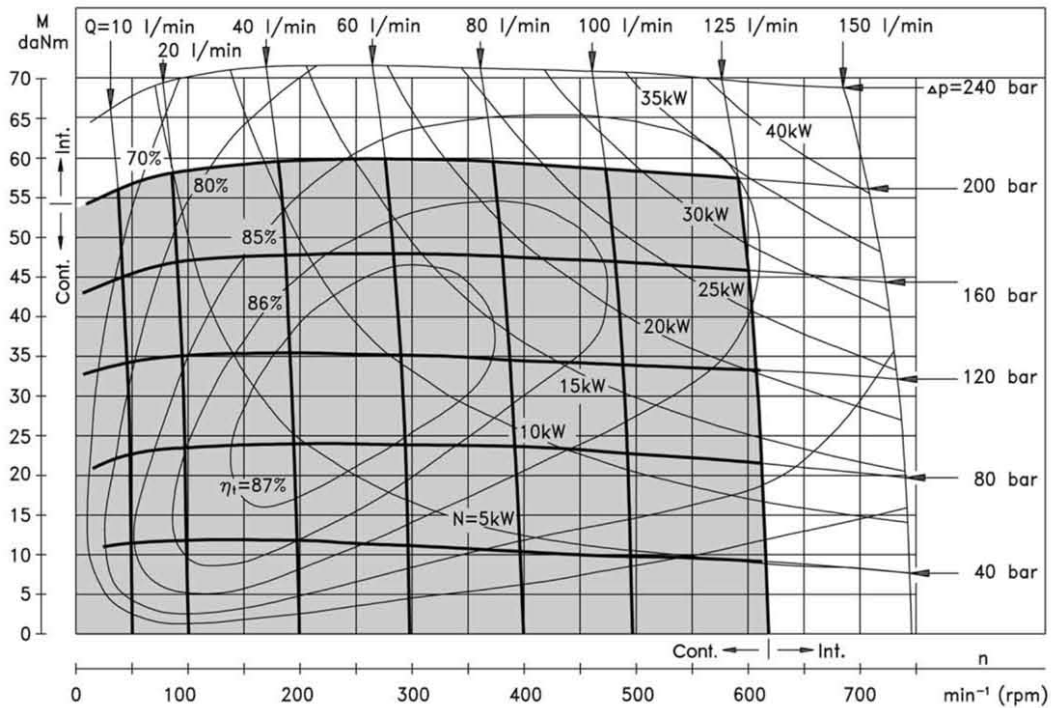

The function diagrams data was collected at back pressure 5 ÷ 10 bar and oil with viscosity of 32 mm<sup>2</sup>/s at 50° C.

## FUNCTION DIAGRAMS

### MT 250

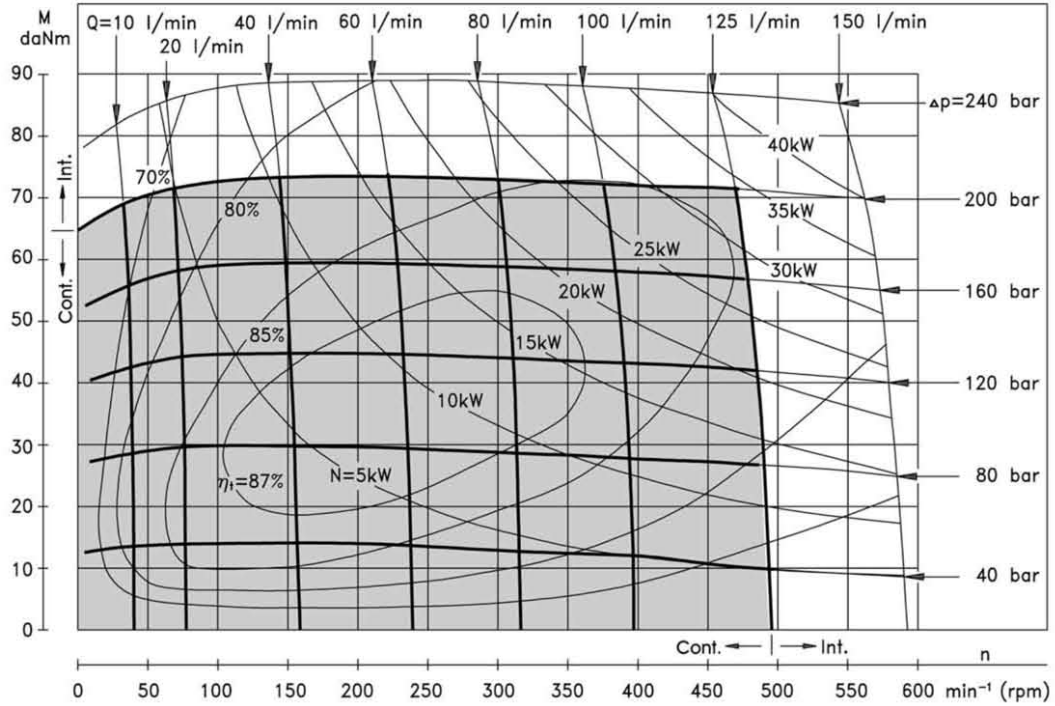

### MT 315

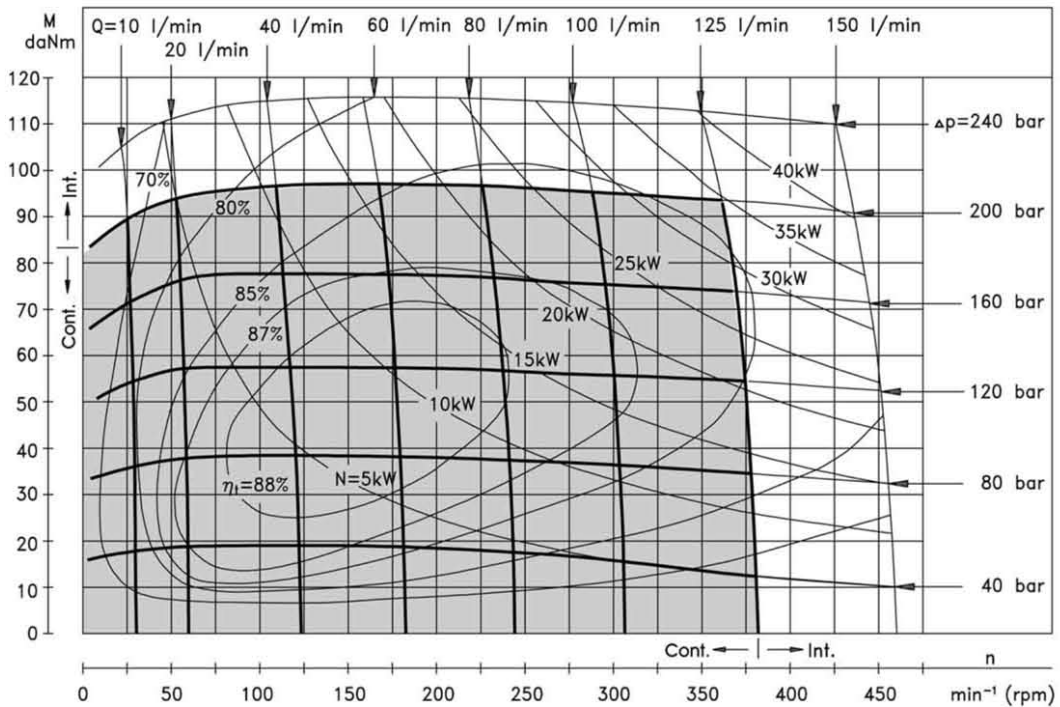

## FUNCTION DIAGRAMS

### MT 400

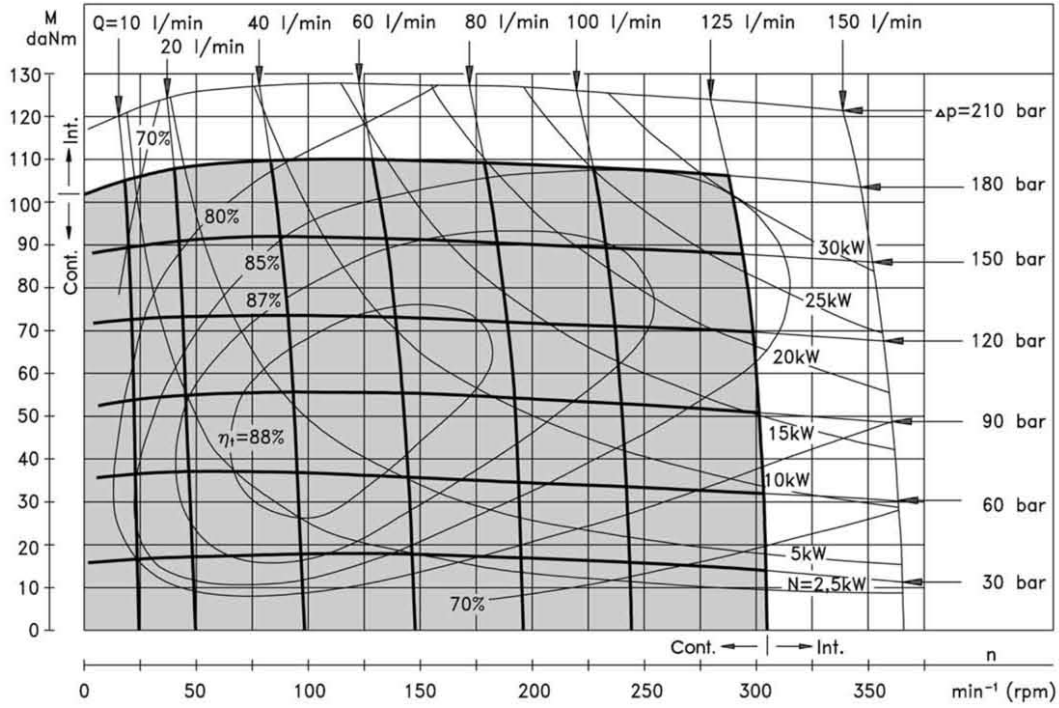

### MT 500

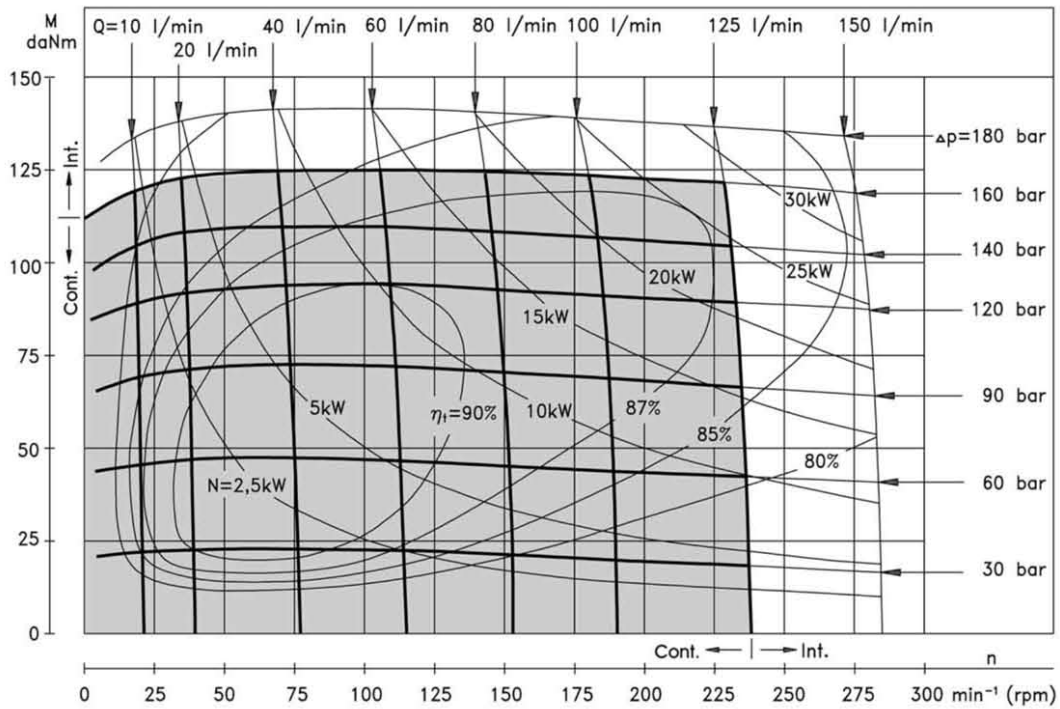

The function diagrams data was collected at back pressure  $5 \div 10$  bar and oil with viscosity of  $32 \text{ mm}^2/\text{s}$  at  $50^\circ \text{C}$ .

## DIMENSIONS AND MOUNTING DATA

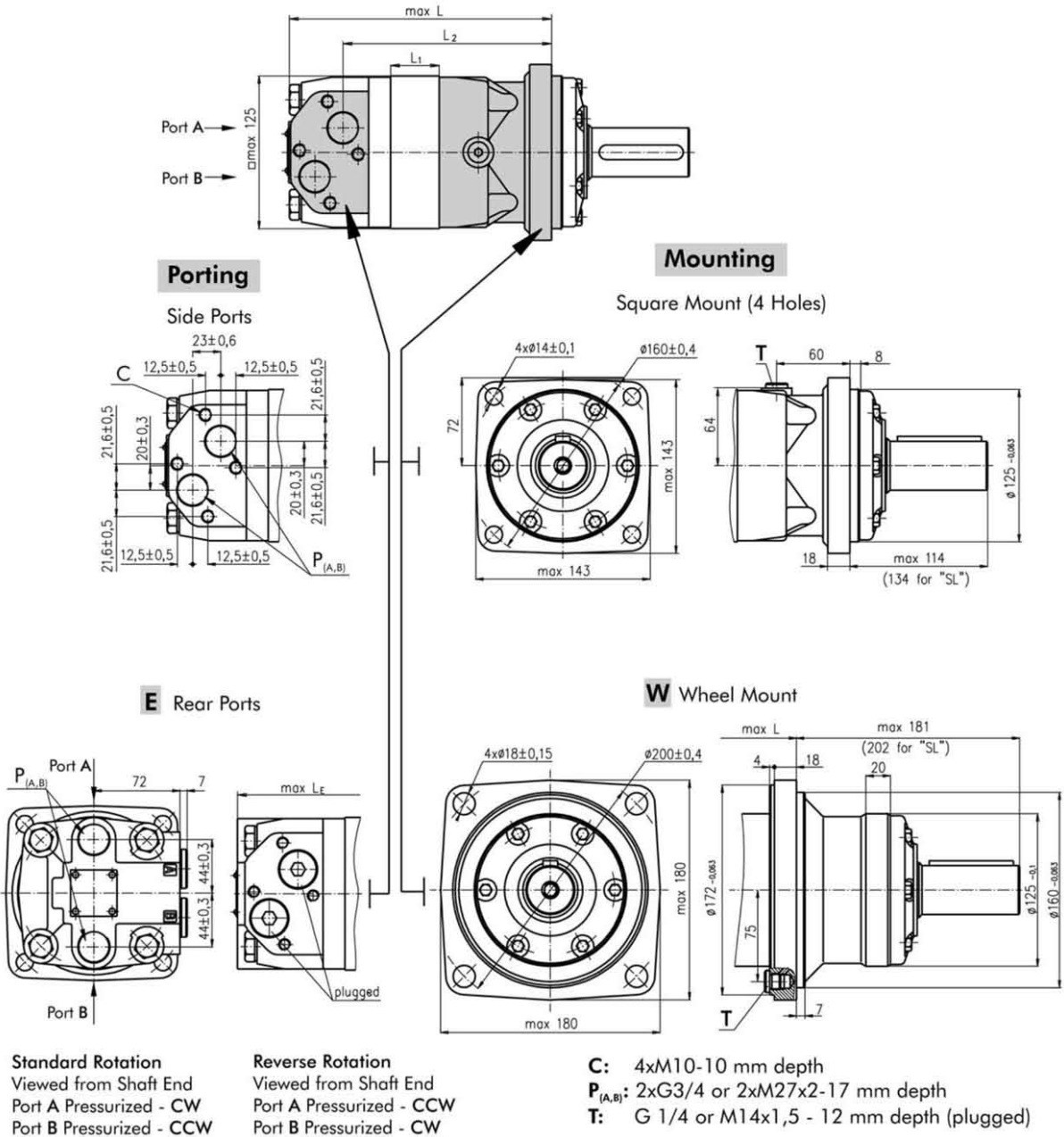

Type	L, mm	Type	L <sub>E</sub> , mm	L <sub>2</sub> , mm	Type	L, mm	Type	L <sub>E</sub> , mm	L <sub>2</sub> , mm	L <sub>1</sub> , mm
MT 160	195	MTE 160	200	147	MTW 160	128	MTWE 160	133	80	20
MT 200	200	MTE 200	205	152	MTW 200	133	MTWE 200	138	85	25
MT 250	206	MTE 250	211	158	MTW 250	139	MTWE 250	144	91	31,3
MT 315	216	MTE 315	221	168	MTW 315	149	MTWE 315	154	101	40,5
MT 400	226	MTE 400	231	178	MTW 400	159	MTWE 400	164	111	51
MT 500	240	MTE 500	245	192	MTW 500	173	MTWE 500	178	125	65



## DIMENSIONS AND MOUNTING DATA - MTS and MTV

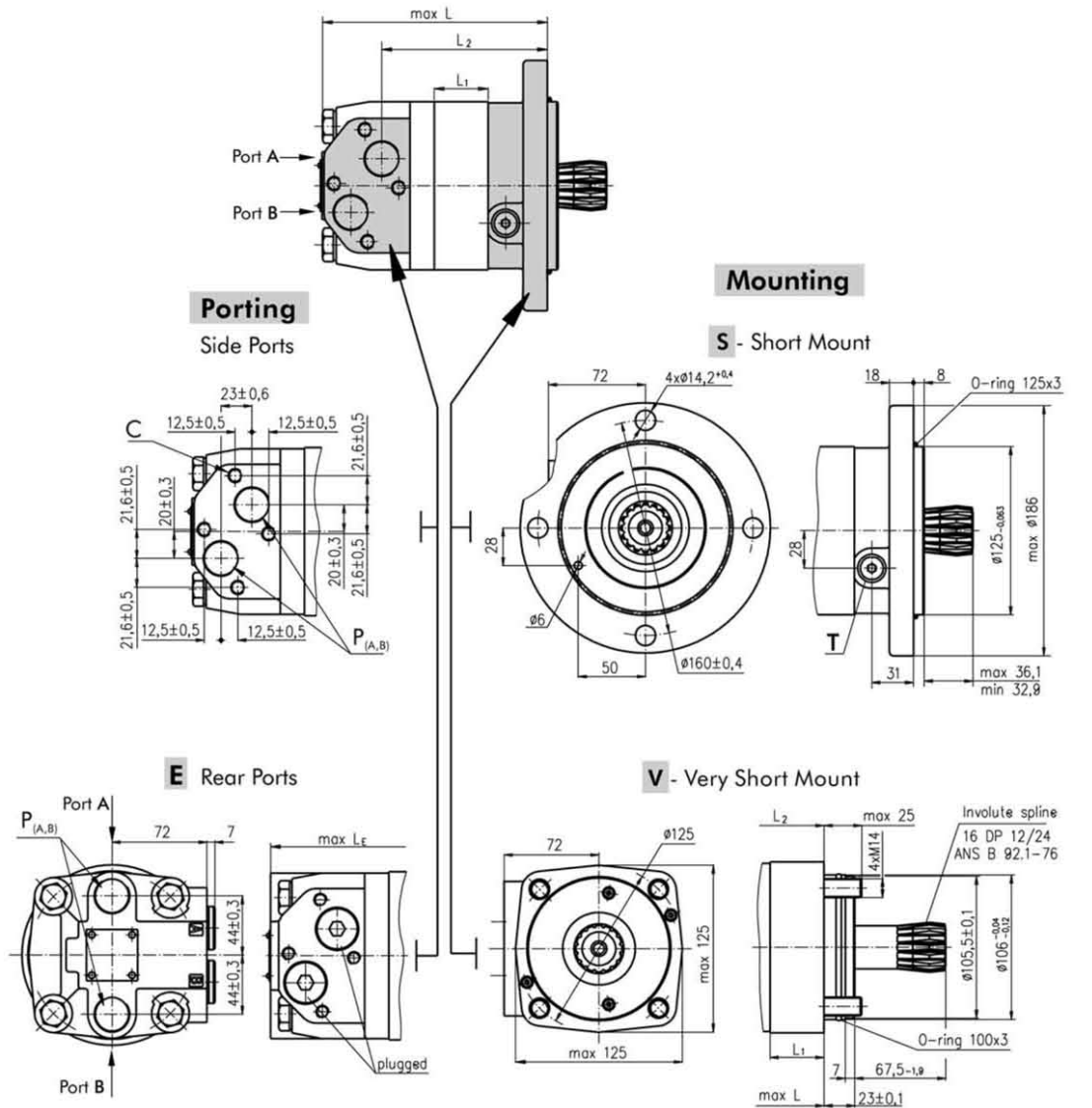

Type	L, mm	Type	L, mm	L <sub>2</sub> , mm	Type	L, mm	Type	L, mm	L <sub>2</sub> , mm	L <sub>1</sub> , mm
MTS 160	151	MTSE 160	156	103	MTV 160	106	MTVE 160	111	58,5	20
MTS 200	156	MTSE 200	161	108	MTV 200	111	MTVE 200	116	63,5	25
MTS 250	162	MTSE 250	167	115	MTV 250	117	MTVE 250	122	70,8	31,3
MTS 315	171	MTSE 315	176	123	MTV 315	126	MTVE 315	131	79	40,5
MTS 400	182	MTSE 400	187	134	MTV 400	137	MTVE 400	142	89,5	51
MTS 500	196	MTSE 500	201	149	MTV 500	151	MTVE 500	156	103,5	65



## DIMENSIONS OF THE ATTACHED COMPONENT

### MTS

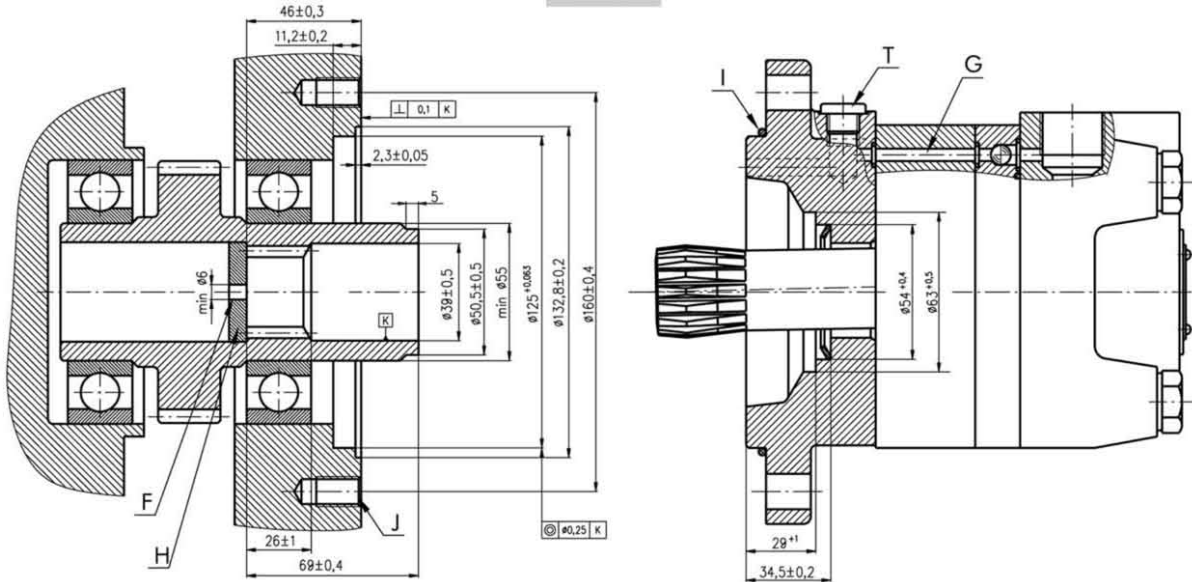

**F:** Oil circulation hole  
**G:** Internal drain channel  
**H:** Hardened stop plate

**I:** O- Ring 125x3mm  
**J:** 4xM12-18 mm depth, 90°  
**T:** Drain connection G1/4 or M14x1,5

### MTV

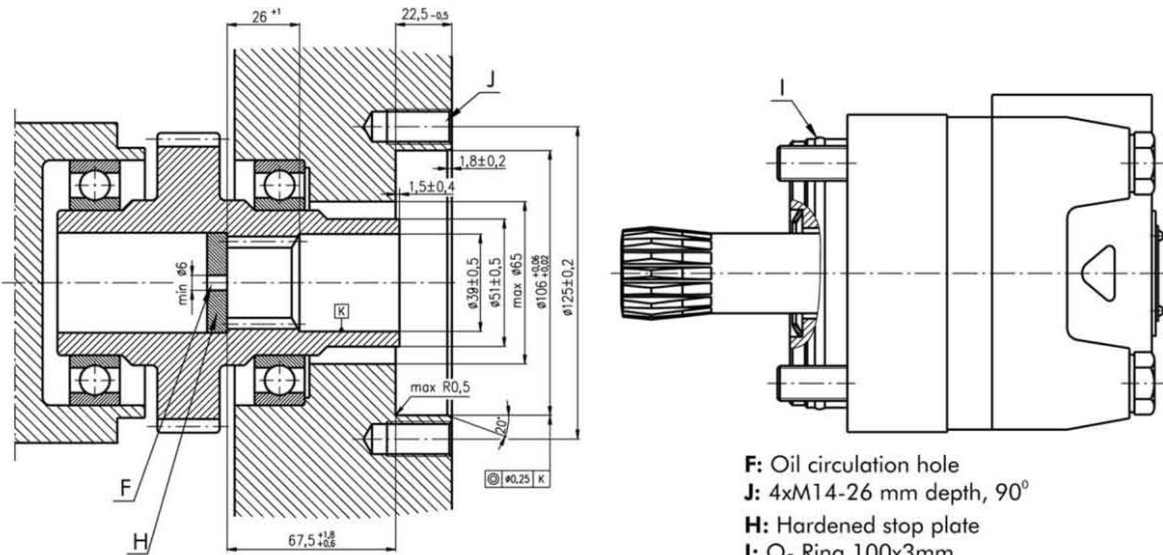

**F:** Oil circulation hole  
**J:** 4xM14-26 mm depth, 90°  
**H:** Hardened stop plate  
**I:** O- Ring 100x3mm

## DRAIN CONNECTION

A drain line ought to be used when pressure in the return line can exceed the permissible pressure. It can be connected:

- For MTS at the drain port of the motor;
- For MTV at the drain connection of the attached component. The maximum pressure in the drain line is limited by the attached component and its shaft seal.

The drain line must be possible for oil to flow freely between motor and attached component and must be led to the tank. The maximum pressure in the drain line is limited by the attached component and its seal.

## INTERNAL SPLINE DATA FOR THE ATTACHED COMPONENT

Standard ANSI B92.1-1976, class 5  
 [m=2.1166; corrected x.m=+1,0]

Fillet Root Side Fit		mm
Number of Teeth	z	16
Diametral Pitch	DP	12/24
Pressure Angle		30°
Pitch Dia.	D	33,8656
Major Dia.	D <sub>ri</sub>	38,4 <sup>+0,4</sup>
Minor Dia.	D <sub>i</sub>	32,15 <sup>+0,04</sup>
Space Width [Circular]	Lo	4,516±0,037
Fillet Radius	R	0,5
Max. Measurement between Pin	L	26,9 <sup>+0,10</sup>
Pin Dia.	d	4,835±0,001

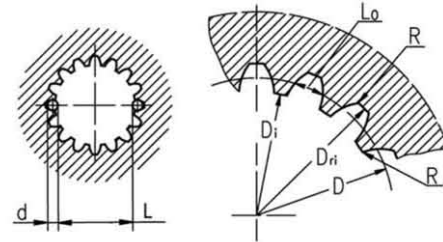

Hardening Specification:

HRC 60±2

HRC 52

0,7±0,2 mm effective case depth

Material 20 MoCr4 DIN 17210 or better

## PERMISSIBLE SHAFT LOADS

The output shaft runs in tapered bearings that permit high axial and radial forces.

Curve "1" shows max. radial shaft load. Any shaft load exceeding the values quoted in the curve will seriously reduce motor life. The two other curves apply to a B10 bearing life of 3000 hours at 200 RPM.

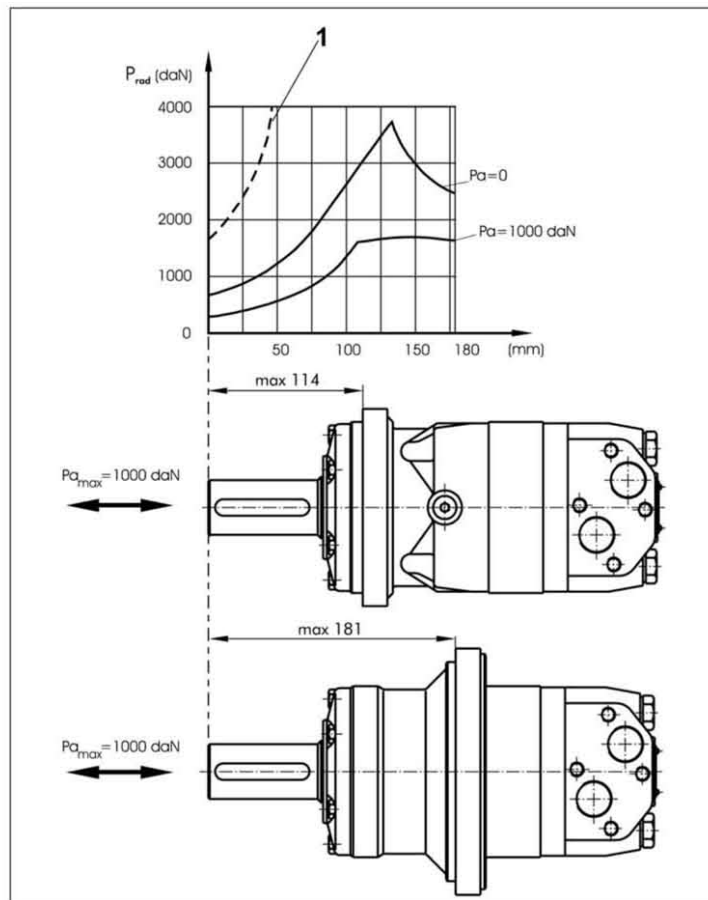

## MOTORS WITH TACHO CONNECTION

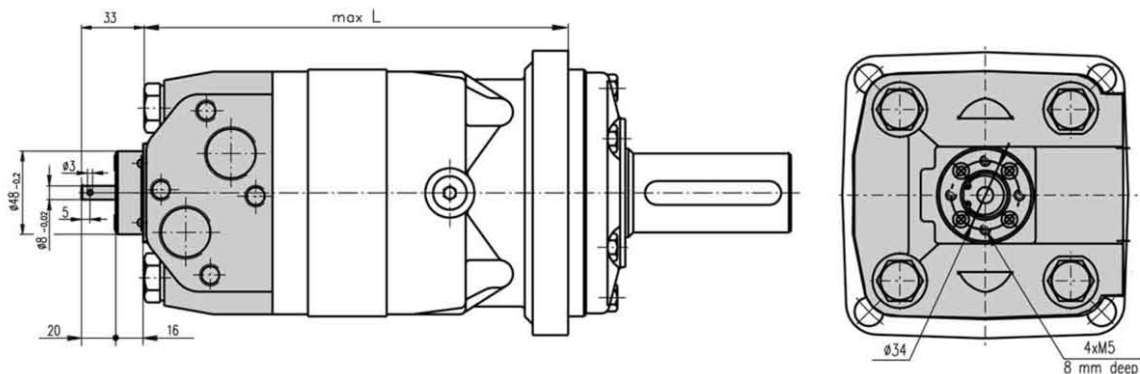

## ORDER CODE

	1	2	3	4	5	6	7
<b>MT</b>							

### Pos.1 - Mounting Flange

omit - Square mount, four holes

**S** - Short mount

**V** - Veryshort mount

**W** - Wheel mount

### Pos.2 - Port type

omit - Side ports

**E** - Rear ports

### Pos.3 - Displacement code

**160** - 161,1[cm<sup>3</sup>/rev]

**200** - 201,4[cm<sup>3</sup>/rev]

**250** - 251,8[cm<sup>3</sup>/rev]

**315** - 326,3[cm<sup>3</sup>/rev]

**400** - 410,9[cm<sup>3</sup>/rev]

**500** - 523,6[cm<sup>3</sup>/rev]

### Pos.4 - Shaft Extensions\*

**C** -  $\varnothing 40$  straight, Parallel key A12x8x70 DIN6885

**CO** -  $\varnothing 1\frac{1}{2}$ " straight, Parallel key  $\frac{3}{8}$ "x $\frac{3}{8}$ "x $2\frac{1}{4}$ " BS46

**K** -  $\varnothing 45$  tapered 1:10, Parallel key B12x8x28 DIN6885

**SL** -  $\varnothing 34,85$  p.t.o. DIN 9611 Form 1

**SH** -  $\varnothing 1\frac{1}{2}$ " splined 17T ANSI B92.1-1976

### Pos. 5 - Ports

omit - BSPP (ISO 228)

**M** - Metric (ISO 262)

### Pos. 6 - Special Features [\(see page 50\)](#)

### Pos. 7 - Design Series

omit - Factory specified

## NOTES:

\* The permissible output torque for shafts must not be exceeded!

The hydraulic motors are mangano-phosphatized as standard.